

Monetary Policy in a Macro Model

ECON 40364: Monetary Theory & Policy

Eric Sims

University of Notre Dame

Spring 2022

Readings

- ▶ Mishkin Ch. 20
- ▶ Mishkin Ch. 21
- ▶ Mishkin Ch. 22
- ▶ Mishkin Ch. 23, pg. 553-569

Approach

- ▶ Want to study role of monetary policy in the aggregate economy
- ▶ For that reason, we will not bother to “micro-found” the macro model of the economy (unlike, for example, in intermediate macro)
- ▶ We will just posit a bunch of demand and supply relationships so as to get a useable demand-supply macro model
- ▶ These demand and supply relationships (or something that looks like them) **can** be motivated from micro principles

Aggregate Demand

- ▶ Aggregate demand is the sum of planned expenditure by the four primary actors in an economy:
 1. Households (consumption)
 2. Firms (investment)
 3. Government (government purchases)
 4. Rest of the world (net exports)
- ▶ Total (real) aggregate demand is the sum of planned expenditure by each of these actors:

$$Y^{ad} = C + I + G + NX$$

- ▶ In equilibrium, $Y^{ad} = Y$ (expenditure equals income)
- ▶ This is somewhat complicated because expenditure categories on right hand side may depend on Y
- ▶ These are flow concepts but will follow book with no explicit time subscripts

Consumption

- ▶ It is assumed that aggregate consumption is governed by a consumption function:

$$C = \bar{C} + mpc \times (Y - T)$$

- ▶ Y is income and T is taxes, so $Y - T$ is disposable income
- ▶ \bar{C} is *autonomous* consumption. “Autonomous” means the exogenous component of an endogenous variable. \bar{C} is consumption independent of disposable income. Potential factors impacting it (which are not modeled explicitly):
 - ▶ Future income
 - ▶ Interest rates
 - ▶ Uncertainty
 - ▶ Government spending (via Ricardian Equivalence)
- ▶ mpc is the marginal propensity to consume and is between 0 and 1
- ▶ Something like this can be derived from micro principles

Investment

- ▶ Investment refers to expenses by business on new physical capital (as well as new residential construction and inventory accumulation)

- ▶ Investment function:

$$I = \bar{I} - dr$$

- ▶ r is “the” real interest rate, d is a parameter governing sensitivity to the real interest rate, and \bar{I} is autonomous investment (investment independent of the real interest rate).

Possible factors:

- ▶ Expectations about the future
 - ▶ Efficiency of producing new capital
 - ▶ Government regulations and taxes
- ▶ Book includes a “credit spread” variable here. We will return to that later

Government Spending and Taxes

- ▶ We assume that government spending and taxes are completely exogenous. Hence:

$$G = \bar{G} \quad (1)$$

$$T = \bar{T} \quad (2)$$

- ▶ We do not think explicitly about government debt, future taxes, or future spending. Also, taxes are “lump sum”
- ▶ Not modeling Ricardian Equivalence

Net Exports

- ▶ Net exports depend on the exchange rate (how much one currency buys of another), as well as on other non-modeled things
- ▶ A high US interest rate results in an appreciation of the dollar other things being equal (foreigners want to buy US assets, pushing up the value of the dollar relative to other currencies)
- ▶ An appreciation of the dollar leads to more imports (cheaper for US citizens to buy foreign goods) and fewer exports (more expensive for foreigners to buy US goods) and hence reduces net exports
- ▶ Net export function, where \bar{NX} is autonomous net exports and x is a parameter governing sensitivity to real interest rate:

$$NX = \bar{NX} - xr$$

Putting it all together

- ▶ Total planned (or desired) expenditure:

$$Y^{ad} = \bar{C} - mpc\bar{T} + \bar{I} + \bar{G} + \bar{N}X + mpcY - (d + x)r$$

- ▶ For simplicity, let $\bar{A} = \bar{C} - mpc\bar{T} + \bar{I} + \bar{G} + \bar{N}X$
- ▶ Then:

$$Y^{ad} = \bar{A} + mpcY - (d + x)r$$

- ▶ One equation in three “unknowns” (Y^{ad} , Y , and r); d , x , and mpc are parameters, and \bar{A} is exogenous
- ▶ In equilibrium, total output must equal total planned expenditure, $Y = Y^{ad}$, so:

$$Y = \frac{1}{1 - mpc}\bar{A} - \frac{d + x}{1 - mpc}r$$

Keynesian Cross

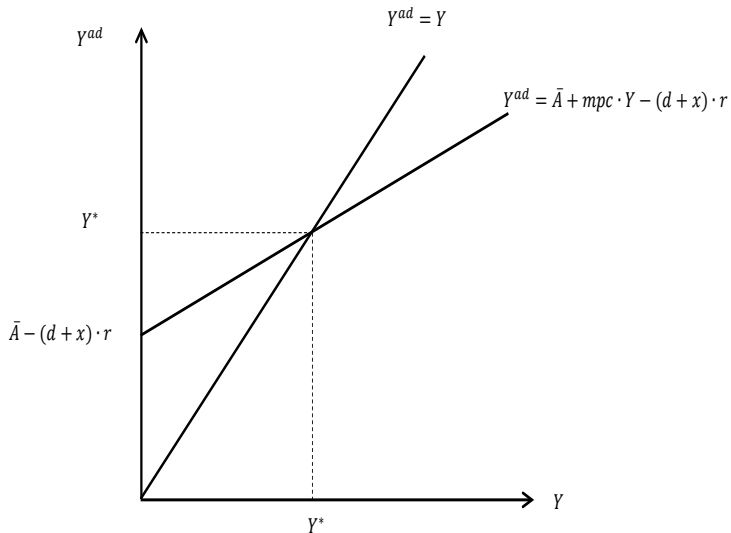

The IS Curve

- ▶ The condition:

$$Y = \frac{1}{1 - mpc} \bar{A} - \frac{d + x}{1 - mpc} r$$

Is one equation in two endogenous variables, r and Y

- ▶ The IS curve is the set of (r, Y) pairs where this condition holds
- ▶ It can be derived graphically:
 - ▶ It is downward sloping
 - ▶ It shifts right whenever \bar{A} increases

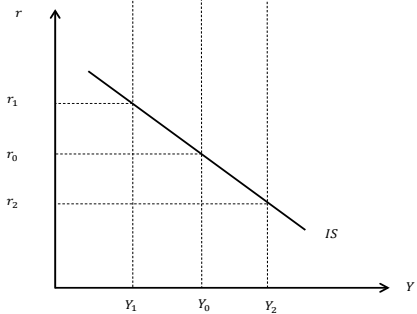
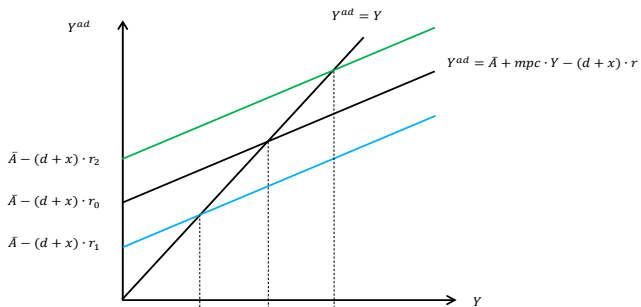

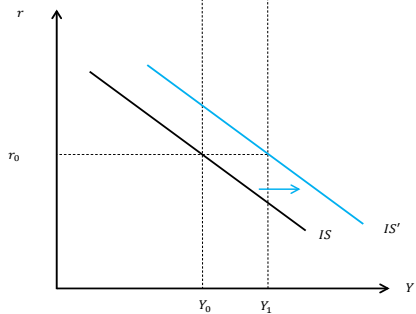
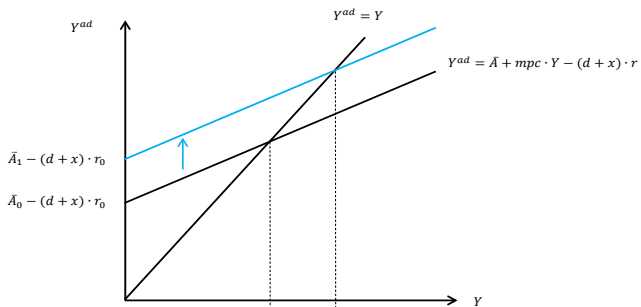

The MP Curve

- ▶ To get an aggregate demand curve, which shows a relationship between aggregate output and the inflation **rate** or the aggregate price **level** (where $\pi = \frac{\Delta P}{P}$), we need to combine the IS curve with some description of monetary policy
- ▶ Traditionally, this is done through something called the LM curve, which combines the liquidity preference of money demand with a money supply rule
- ▶ Given central bank's modern focus on interest rates rather than money supply, we instead do so with the monetary policy curve (MP)
- ▶ Difference: with the LM curve, AD curve is downward-sloping in a graph with (P, Y) . With MP curve, AD curve is downward-sloping with (π, Y)
- ▶ We need not model money at all, though we could figure out how Fed must adjust M to meet money demand if we wanted – the economy is “cashless”

The MP curve and the Taylor Principle

- ▶ Recall the Fisher relationship, $r = i - \pi^e$. Fed can control i , but not necessarily r
- ▶ Assume **adaptive** expectations, so that $\pi^e = \pi$.
- ▶ Then assume Fed sets nominal rate according to:

$$i = \bar{r} + a\pi$$

- ▶ Similar to the Taylor rule. \bar{r} is “autonomous monetary policy” (movements in rates unrelated to inflation). $a > 1$ – the “Taylor Principle”
- ▶ Can write the real interest rate as:

$$r = \bar{r} + \lambda\pi$$

- ▶ Where $\lambda = (a - 1)$. Taylor principle requires $\lambda > 0$. Idea: when π increases, Fed responds by raising i by sufficiently much so as to raise r

The AD Curve

- ▶ Simply combine the IS and MP curves. You get:

$$Y = \frac{1}{1 - mpc} \bar{A} - \frac{d + x}{1 - mpc} (\bar{r} + \lambda \pi)$$

- ▶ Can also re-arrange with π on LHS:

$$\pi = -\frac{1 - mpc}{(d + x)\lambda} Y + \frac{1}{(d + x)\lambda} \bar{A} - \frac{1}{\lambda} \bar{r}$$

- ▶ Provided $\lambda > 0$ (Taylor principle satisfied):
 1. AD curve is downward-sloping
 2. AD curve is flatter the bigger is λ
 3. AD curve shifts out/up when \bar{A} increases
 4. AD curve shifts down/in when \bar{r} increases

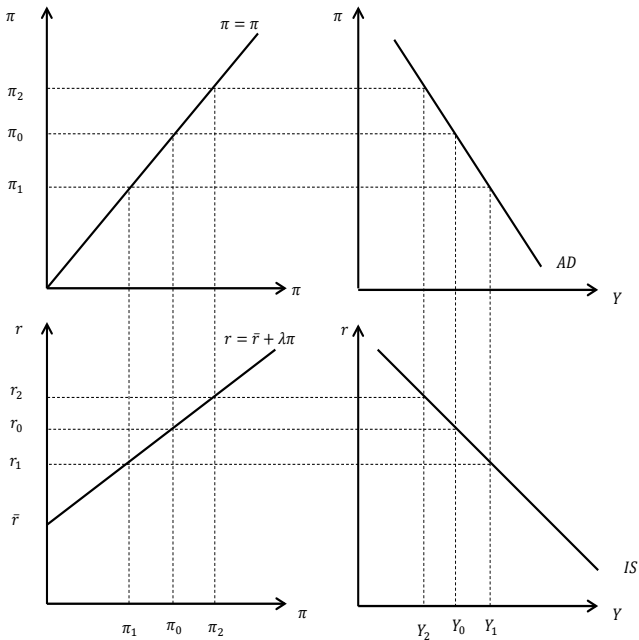

Shifts of the AD Curve

- ▶ The AD curve is drawn holding \bar{r} (which governs the position of the MP curve) and \bar{A} (which governs the position of the IS curve) fixed
- ▶ An increase in \bar{r} will result in an increase in the real interest rate for a given inflation rate; from the IS curve, this results in a lower level of output. So the AD curve shifts left
- ▶ An increase in \bar{A} will shift the IS curve right. For a given inflation rate, the real interest rate is given, which means that output increases. So the AD curve shifts right

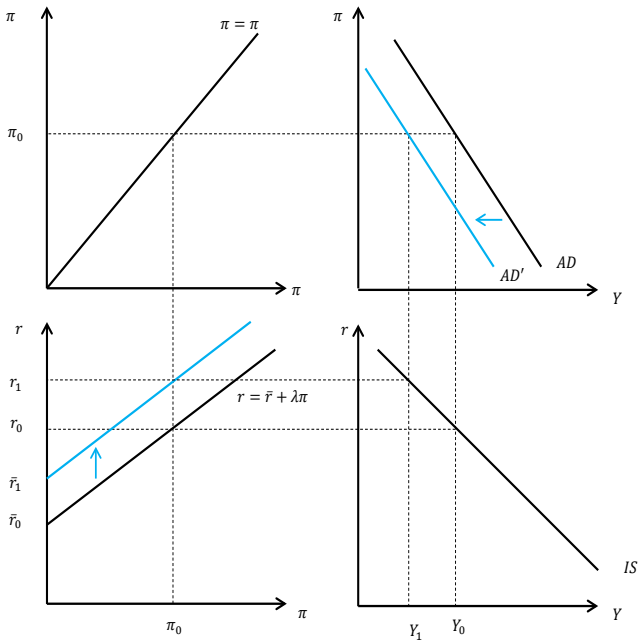

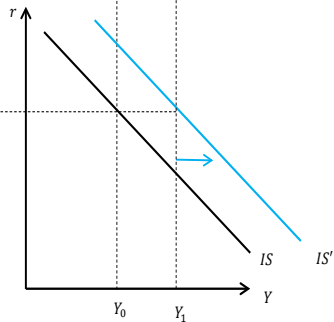
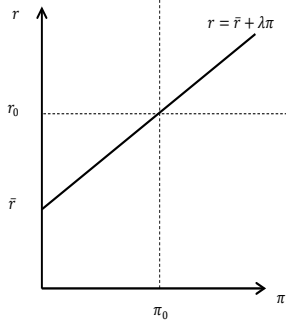
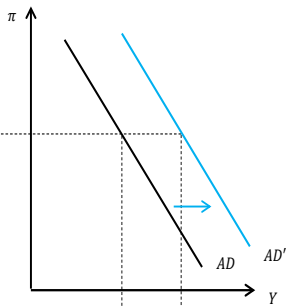
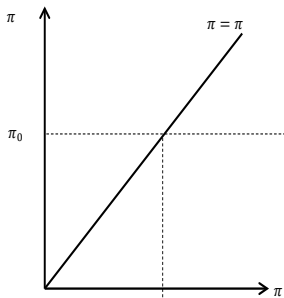

The Taylor Principle and the Slope of the AD Curve

- ▶ The Taylor principle ($a > 1$ or $\lambda > 0$) calls for the Fed to raise the real interest rate when inflation increases
- ▶ The higher real interest rate causes output to decline from the IS curve, which makes the AD curve downward-sloping
- ▶ What if the Taylor principle isn't satisfied? i.e. $\lambda < 0$?
- ▶ Higher inflation results in lower real interest rates, which stimulates output from the IS curve
- ▶ The AD curve is upward-sloping. For reasons we will talk about later, this is undesirable.

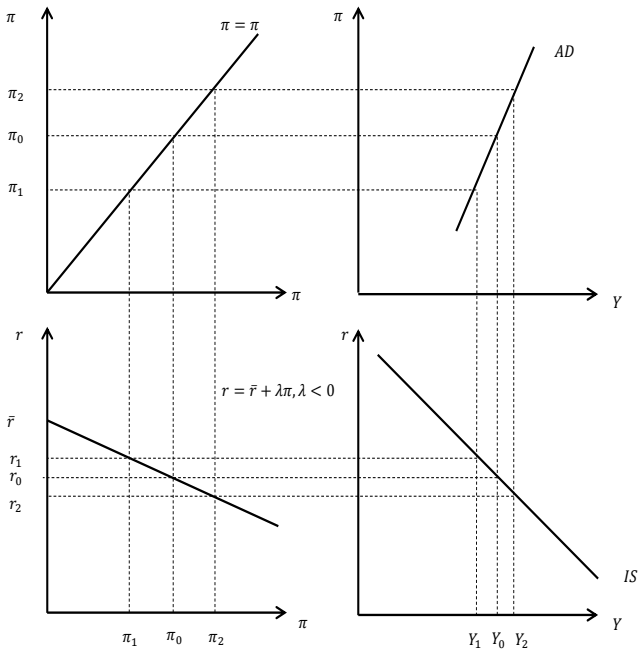

Aggregate Supply

- ▶ Relationship between π and Y (or P and Y)
- ▶ Accepted paradigm:
 - ▶ Aggregate supply (AS) curve is vertical in the “long run” or “medium run.” The level of output where it’s vertical, or “potential output,” is determined by labor supply, available capital, and technology. **Classical dichotomy**: real variables independent of nominal
 - ▶ Prices and/or wages are “sticky” in the short run, so “short run” AS curve is upward-sloping instead of vertical. Classical dichotomy **breaks down**
- ▶ Many policy debates among macroeconomists are over the “shape” of the AS curve (i.e. how far from vertical is the AS curve in the short run) and how long it takes to transition from short run to medium/long run
- ▶ Let Y^P denote potential output; take this to be exogenous (equilibrium concept in model without nominal rigidity)
- ▶ LRAS (long run aggregate supply) is vertical at this point

Short Run AS

- ▶ The assumed short run AS curve is:

$$\pi = \pi^e + \gamma(Y - Y^P) + \rho$$

- ▶ Where:

1. π^e : how much inflation firms/households expected from “yesterday” to “today” (note slightly different than π^e in the Fisher relationship, which is expected inflation from “today” to “tomorrow” . . . this is where time subscripts would be handy)
 2. γ : parameter governing how steep AS is (related to underlying price and/or wage stickiness)
 3. ρ : “inflation shock” (e.g. increase in oil prices), also called “cost-push shock.” Zero on average; if it changes, only changes for one period (simplifying assumption)
- ▶ If $Y > Y^P$, firms/households have pressure to increase prices/wages, which puts upward pressure on π . γ big: it’s easy to do this. γ small: prices/wages are very sticky

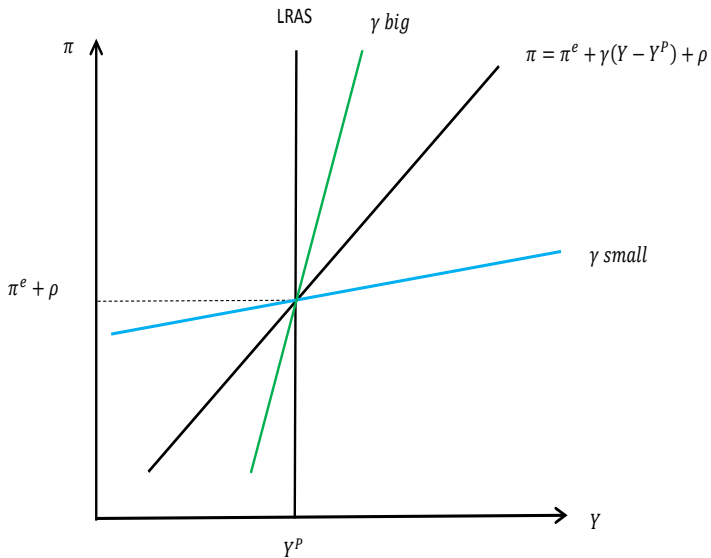

Short Run AS Curve (SRAS)

- ▶ The following are relevant things to remember about the AS curve:
 1. If $\gamma \rightarrow \infty$, no distinction between SRAS and LRAS
 2. AS curve crosses point $Y = Y^P$ at $\pi = \pi^e + \rho$. The inflation shock ρ is zero on average, so we'll often think of this point as being where $\pi = \pi^e$. In other words, if households and firms are not surprised by inflation, then $Y = Y^P$ regardless of what γ is
 - ▶ In a sense, nominal rigidities matter only if agents are "fooled" (Lucas 1972)
 3. The AS curve shifts up if π^e or ρ increase
 4. The AS curve shifts right if Y^P increases

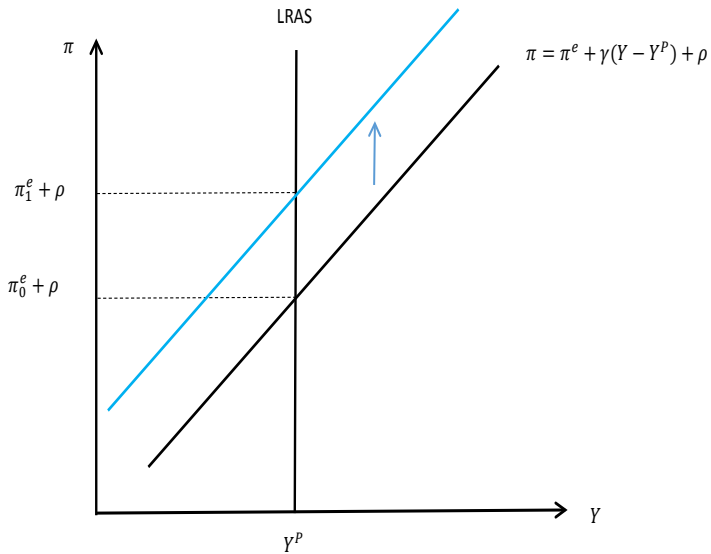

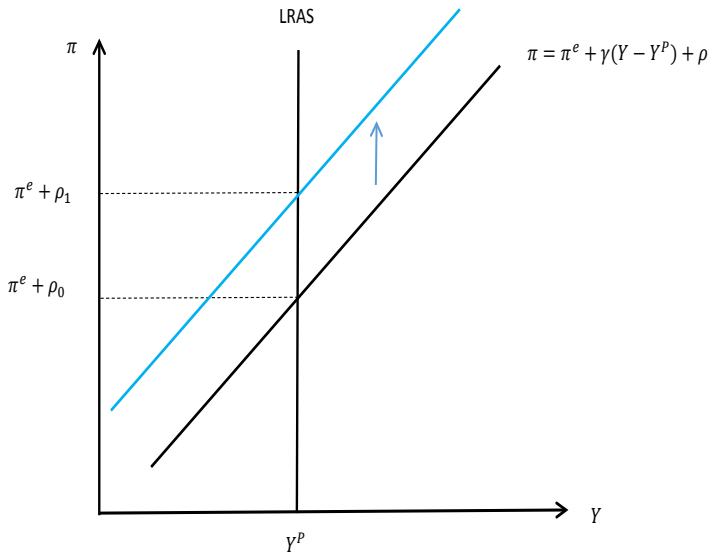

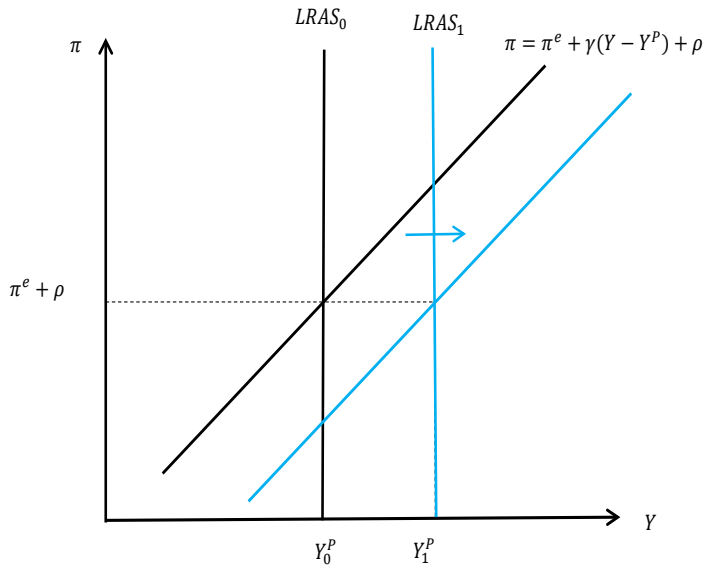

General Equilibrium

- ▶ Equilibrium occurs where AD and AS intersect
- ▶ For simplicity, assume these intersect initially at the LRAS
- ▶ Exogenous variables cause curves to shift and change the equilibrium
 - ▶ Demand shocks:
 - ▶ IS shocks: changes in \bar{A} (\bar{C} , \bar{I} , \bar{T} , \bar{G} , \bar{NX})
 - ▶ Monetary shocks: changes in \bar{r}
 - ▶ Supply shocks:
 - ▶ Potential output shocks: changes in Y^P
 - ▶ Inflation shocks: changes in ρ
 - ▶ Expected inflation shocks: changes in π^e

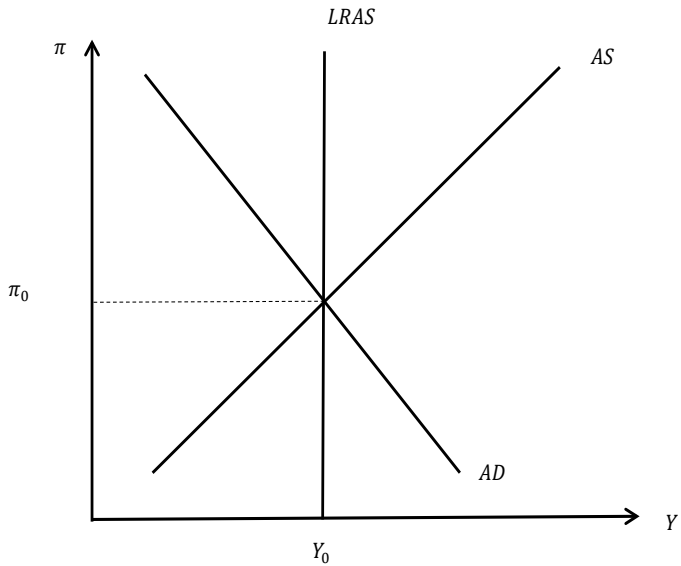

Demand Shock

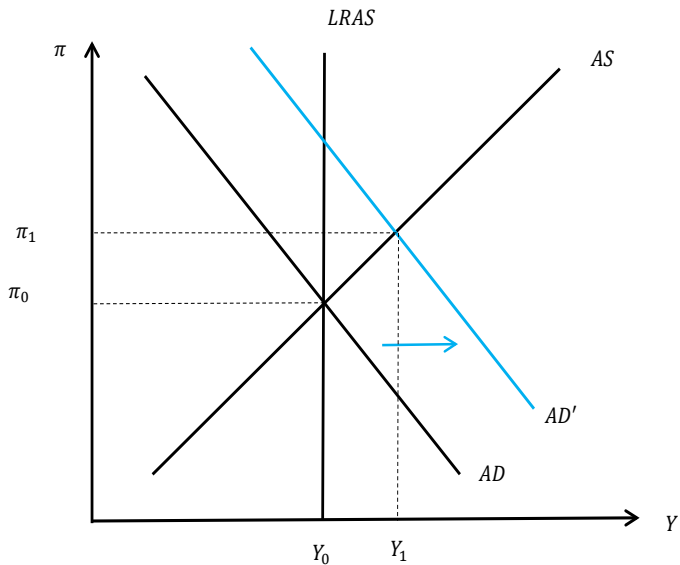

IS Shock: What Happens to r

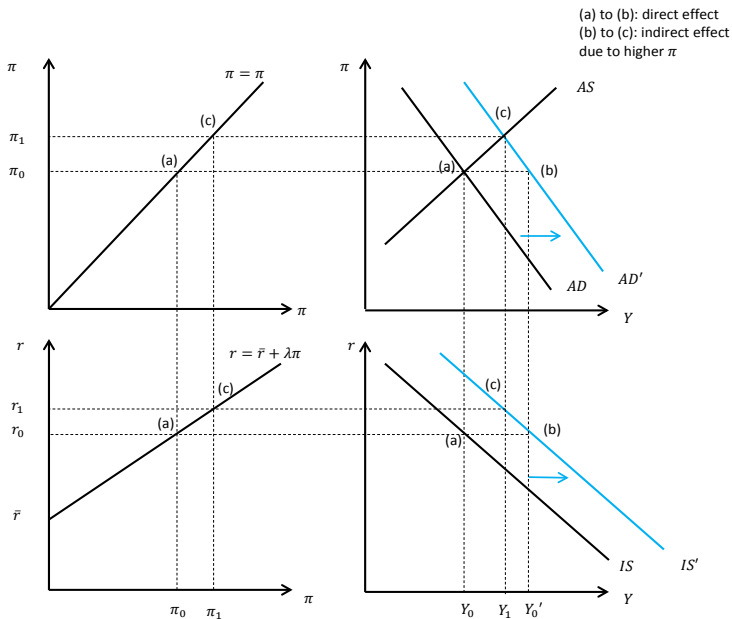

MP Shock: What Happens to r

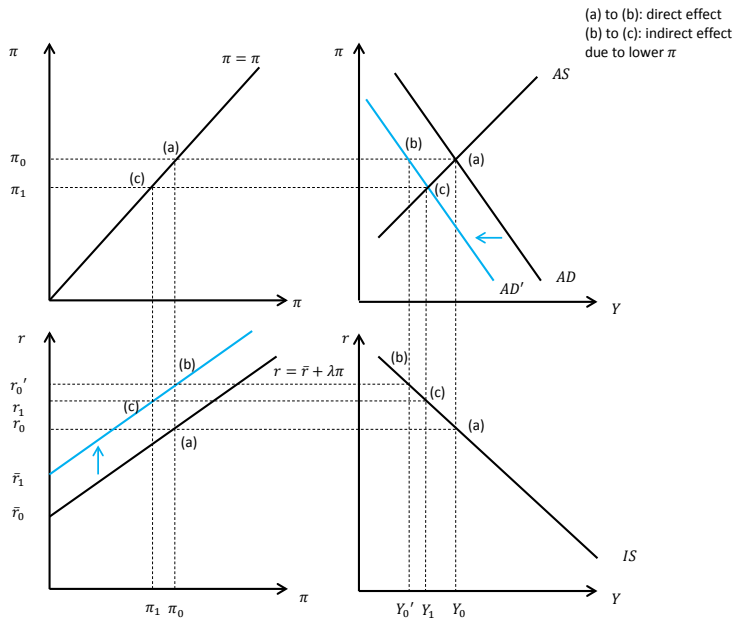

Monetary Neutrality: MP Shock When AS is Vertical

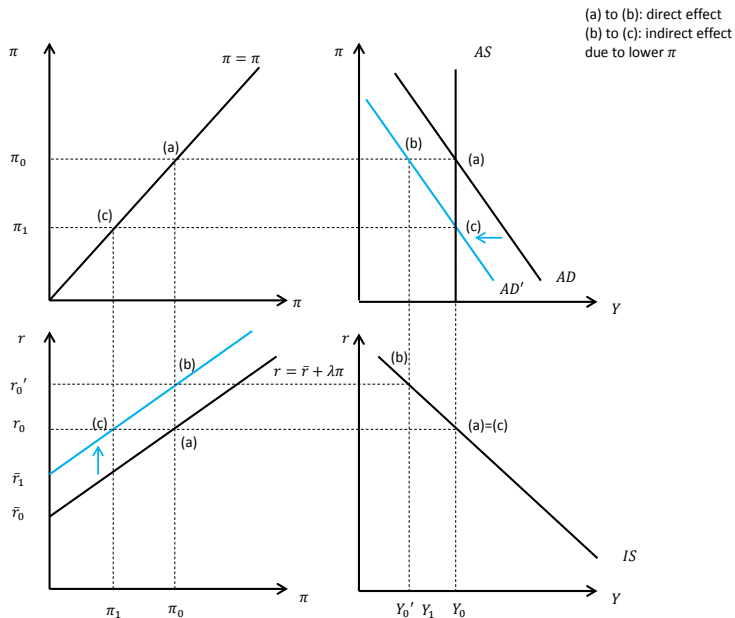

Supply Shock: Increase in π^e or ρ

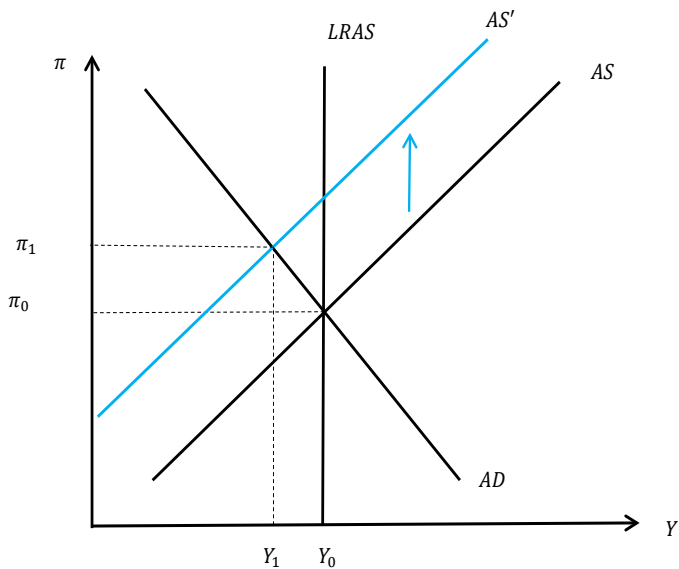

Supply Shock: Increase in Y^P

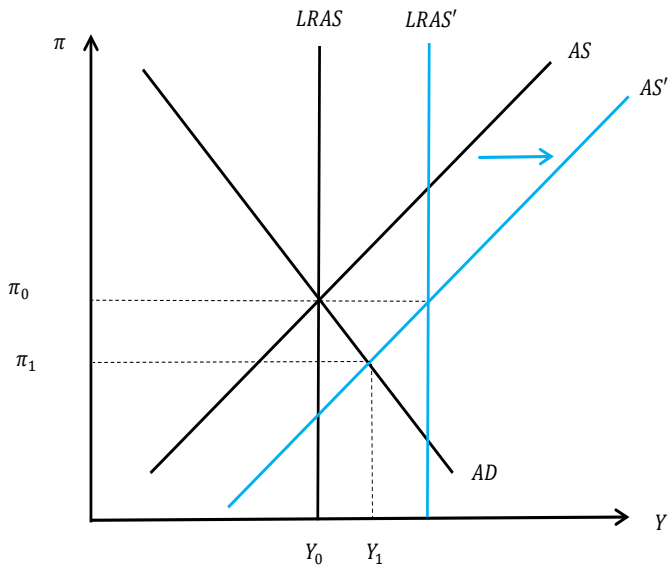

Decrease in Y^P : Effect on r

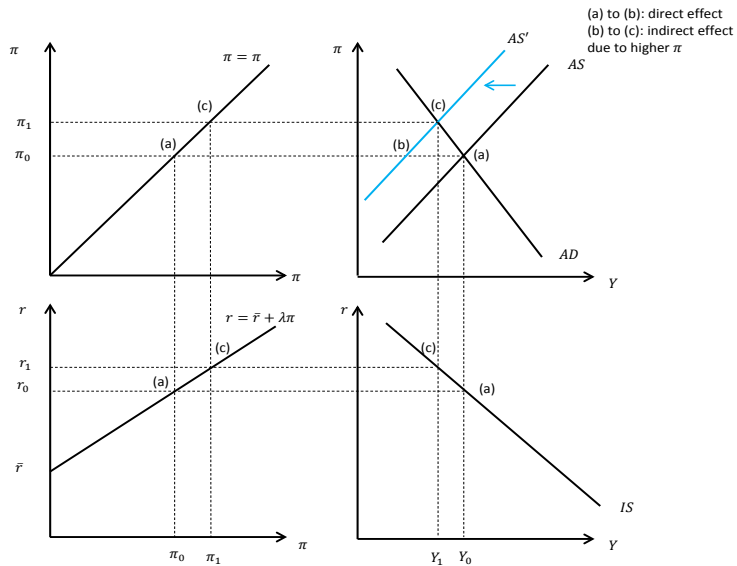

Algebraically Solving for Equilibrium

- ▶ AS with AD:

$$\pi = \pi^e + \gamma \left(\frac{1}{1 - mpc} \bar{A} - \frac{d + x}{1 - mpc} (\bar{r} + \lambda\pi) - Y^P \right) + \rho$$

- ▶ Solve for π :

$$\pi = \frac{1 - mpc}{1 - mpc + (d + x)\lambda\gamma} (\pi^e + \rho) + \frac{\gamma}{1 - mpc + (d + x)\lambda\gamma} \bar{A} - \frac{(d + x)\gamma}{1 - mpc + (d + x)\lambda\gamma} \bar{r} - \frac{\gamma(1 - mpc)}{1 - mpc + (d + x)\lambda\gamma} Y^P$$

- ▶ Once you have this, you can get Y from the AS curve:

$$Y = Y^P + \frac{1}{\gamma} (\pi - \pi^e - \rho)$$

- ▶ Then can get $r = \bar{r} + \lambda\pi$ and components of output

Inflation During the Pandemic



COVID-19 Inflation

- ▶ Initially, inflation fell
 - ▶ Near cessation of economic activity (drop in demand)
 - ▶ Some reduction in potential output (drop in supply)
 - ▶ Net result: fall in inflation, big drop in output
- ▶ Since then, it has picked up and is the highest in 40 years
- ▶ Why?
 1. Massive increase in demand
 - ▶ $\uparrow \bar{B}$, $\downarrow \bar{T}$, $\downarrow \bar{r}$
 - ▶ Central bank asset purchases (not modeled yet)
 2. Supply-chain pressures ($\uparrow \rho$)
 3. Reduction in Y^P

AD-AS Interpretation: COVID-19 in Spring 2020

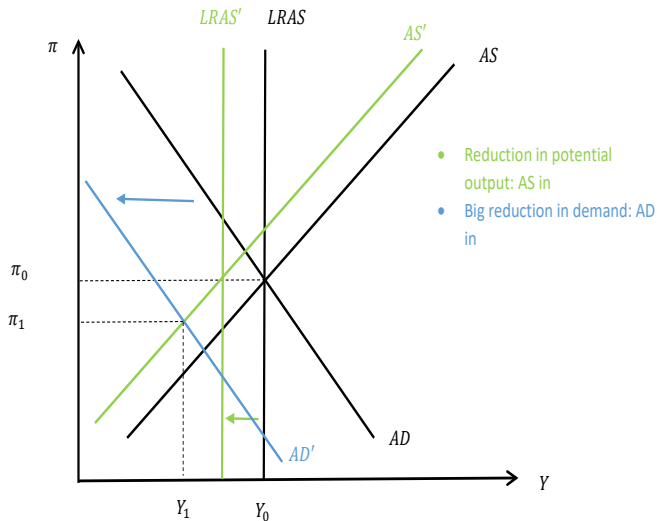

AD-AS Interpretation: COVID-19 Today

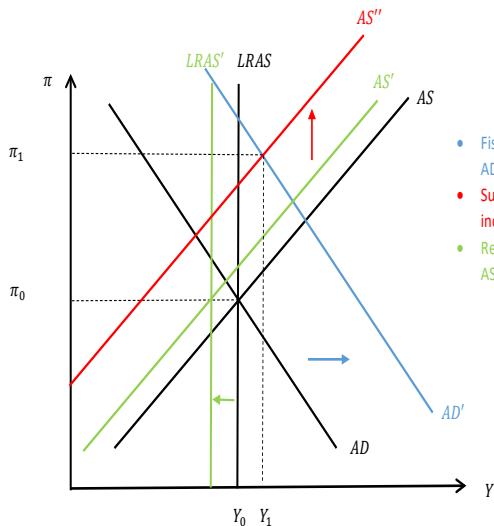

Dynamics and the “Self-Correcting Mechanism”

- ▶ Assume $\rho = 0$ (its average value)
- ▶ From AS, if $Y \neq Y^P$, then $\pi \neq \pi^e$
- ▶ $Y > Y^P \Rightarrow \pi > \pi^e$: agents were surprised with more inflation than they expected
- ▶ Stands to reason that, going forward in time, they will then revise up expectations
- ▶ π^e going up: shifts AS curve up, which makes Y fall with no effect on Y^P
- ▶ This process will continue until $Y = Y^P$ and inflation stops change
- ▶ And vice-versa in the other direction

Adjustment from Positive Gap: Qualitative

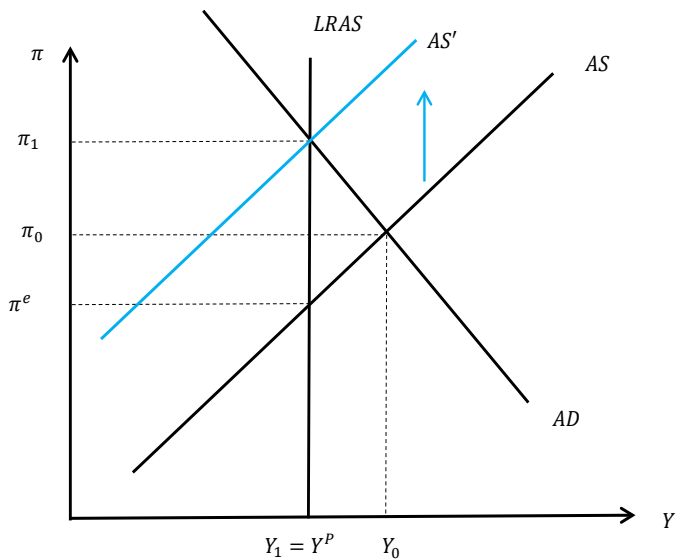

Being More Specific

- ▶ Put time subscripts on all variables: t is present, $t - 1$ is one period in past, $t + 1$ one period in future, and so on
- ▶ Assume adaptive expectations, so that π^e in the AS curve is π_{t-1}
- ▶ Then AS curve is:

$$\pi_t = \pi_{t-1} + \gamma \left(Y_t - Y_t^P \right) + \rho_t$$

- ▶ AD curve is:

$$Y_t = \frac{1}{1 - mpc} \bar{A}_t - \frac{d + x}{1 - mpc} (\bar{r}_t + \lambda \pi_t)$$

- ▶ The interesting dynamics are on the supply side. As π_t changes, the position of the AS curve will change dynamically over time. Assume $\rho_t = 0$ (unconditional mean)
- ▶ Adjustment occurs slowly, only eventually do you get to Y^P

Adjustment from Positive Gap: More Specific

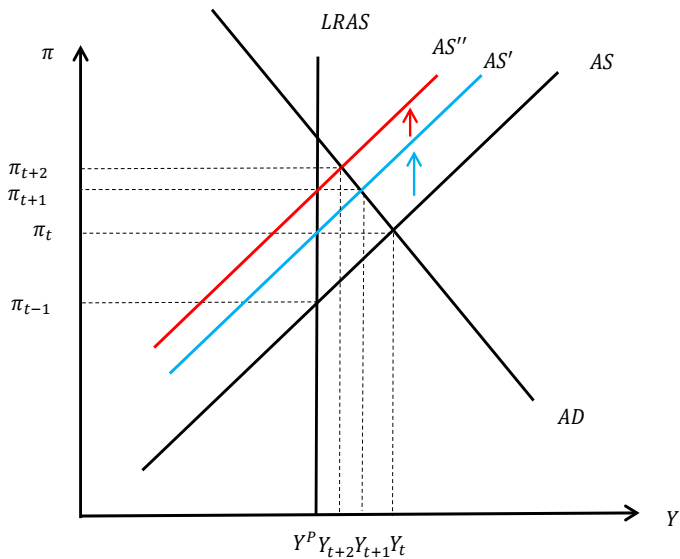

Quantitative Dynamics

- ▶ Create an Excel file
- ▶ Assume the following parameters and exogenous variables:
 $mpc = 0.7$, $d = 0.3$, $x = 0.1$, $\bar{r} = 1$, $\lambda = 1$, $\bar{A} = 4.95$,
 $\gamma = 0.5$, $Y^P = 12.5$
- ▶ Assume $\pi_{t-1} = 0$
- ▶ Implies that $\pi_t = 0.8$ and $Y_t = 14.1$
- ▶ Use Excel to trace out dynamic paths

Adjustment from Positive Gap: Quantitative

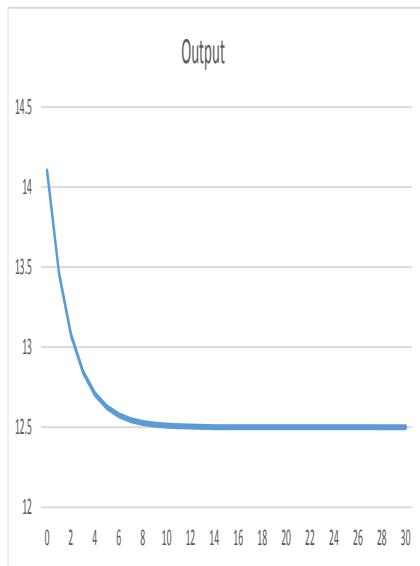
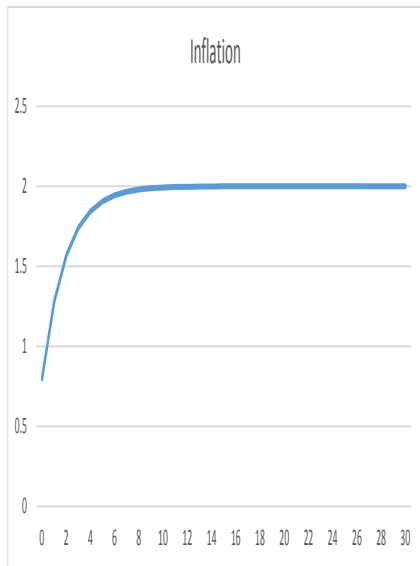

Positive IS Shock: Dynamic Adjustment

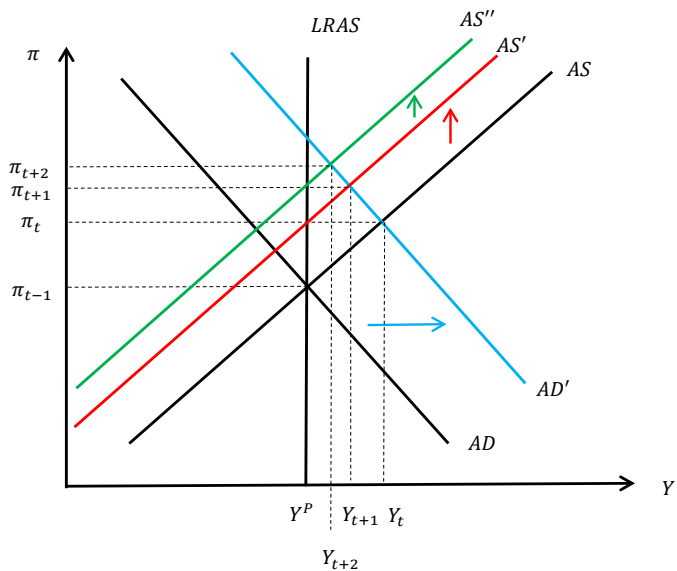

Quantitative Adjustment from Positive IS Shock

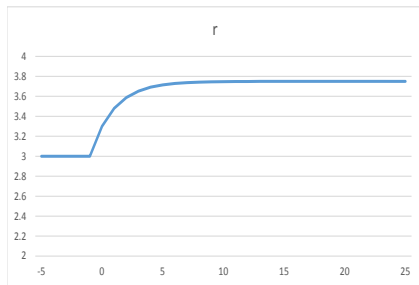
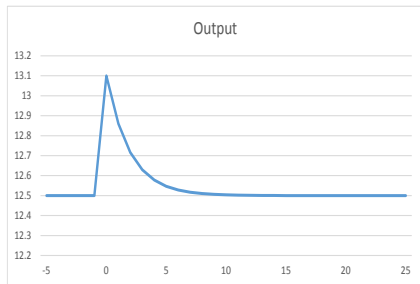
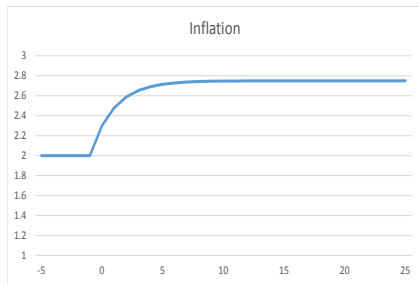

Monetary Shock

- ▶ An exogenous monetary tightening (increase in \bar{r}) has effects in terms of output and inflation similar to an IS shock (exogenous increase in \bar{A})
- ▶ Difference: monetary shock does not affect r_t in medium/long run
- ▶ “Natural rate of interest”: r consistent with IS curve holding at Y^P . Call it r^P (potential or long run real interest rate):

$$r^P = -\frac{1 - mpc}{d + x} Y^P + \frac{1}{d + x} \bar{A}$$

- ▶ Does *not* depend on \bar{r}

Adjustment from Positive \bar{r} Shock

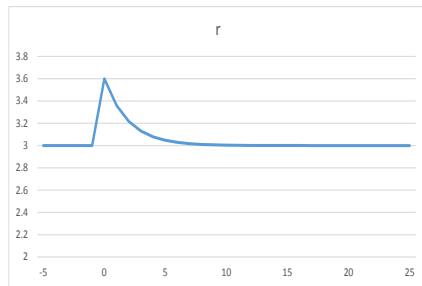
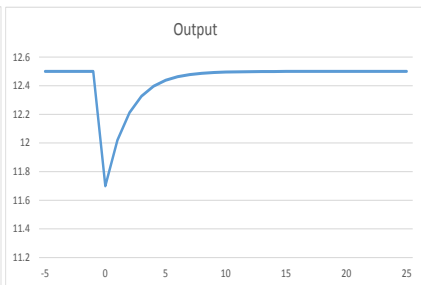
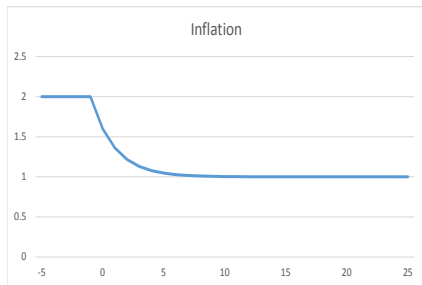

Application: Volcker Disinflation

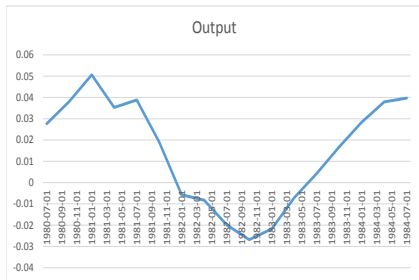
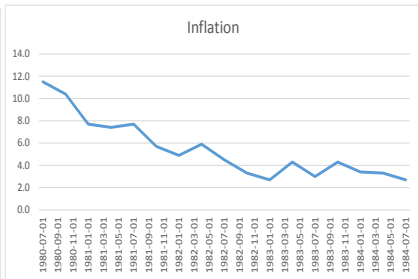
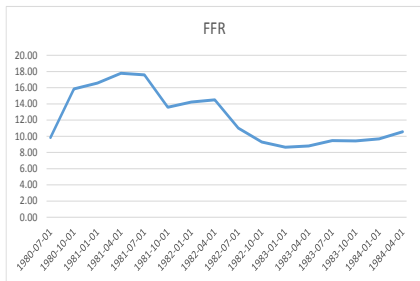

Adjustment from Positive Y^P Shock

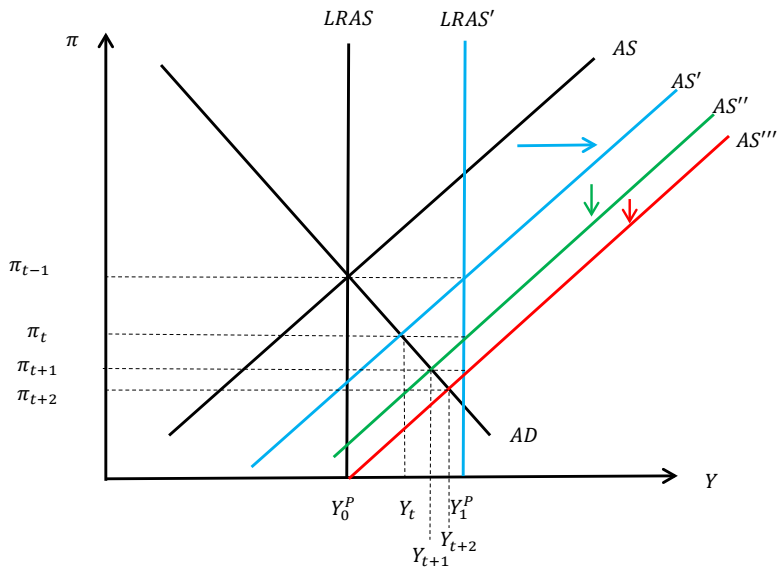

Quantitative Adjustment from Positive Y^P Shock

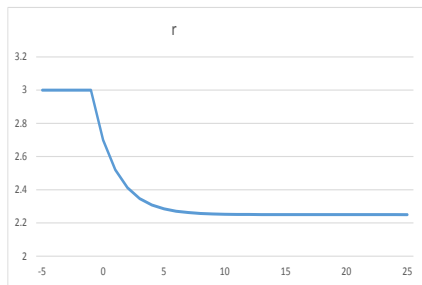
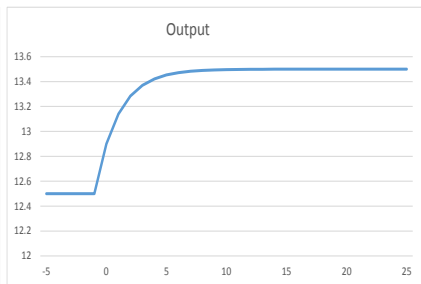
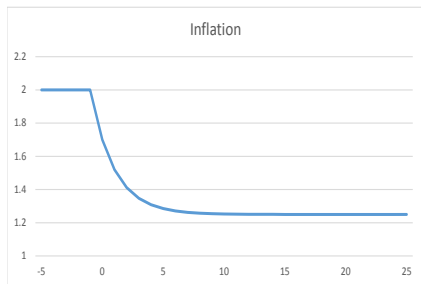

Adjustment from One Period ρ Shock

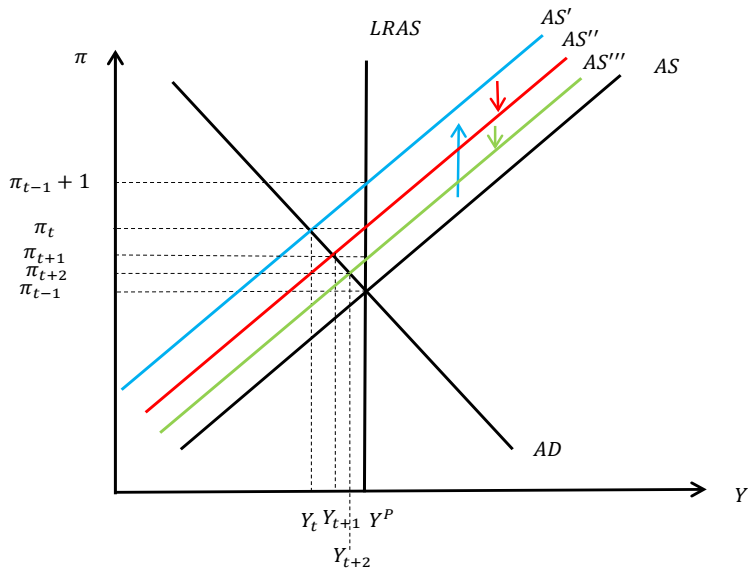

Quantitative Adjustment from Positive ρ Shock

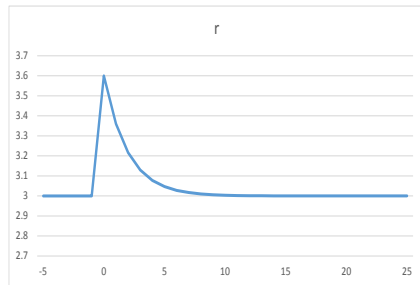
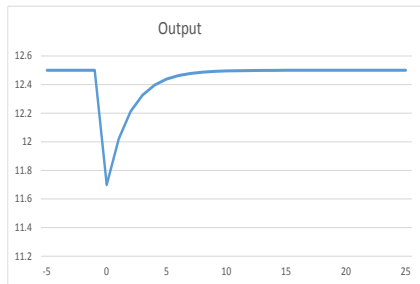
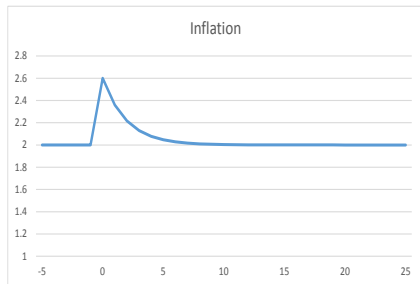

Application: Oil Shocks and Stagflation

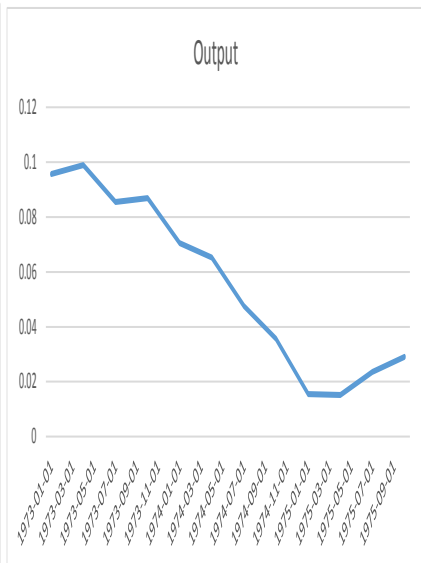
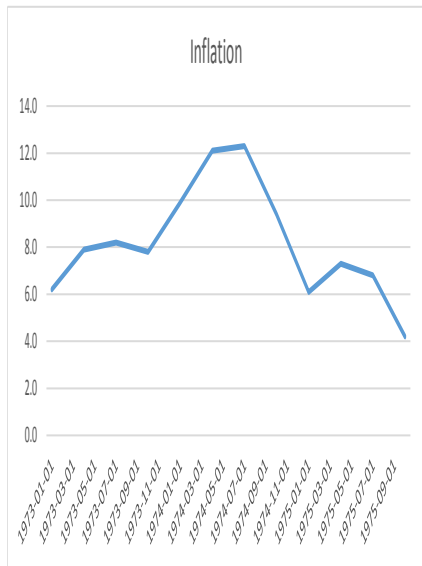

Monetary Policy Objectives

- ▶ When it comes to the business cycle, monetary policy has a **dual mandate**: it wants to stabilize inflation around some low and stable rate and achieve “maximum employment”
- ▶ In the context of our model, we can think about the first half of the mandate as keeping π_t close to constant, and the second half as keeping Y_t close to Y_t^P
- ▶ Define the output gap as $X_t = Y_t - Y_t^P$
- ▶ Hence, objectives are to keep π_t close to constant and X_t close to zero
- ▶ NOTE: in August 2020 Fed announced changes in operating framework:
 - ▶ Have inflation be stable **on average** (average inflation targeting)
 - ▶ Focus more on **shortfalls** from “full employment” more so than deviations

Monetary Policy Tools

- ▶ The primary tool of monetary policy (in this simple model) is the parameter λ
- ▶ Governs how strongly policy reacts to inflation
- ▶ Recall algebraic expression for AD curve:

$$\pi = -\frac{1 - mpc}{(d + x)\lambda} Y + \frac{1}{(d + x)\lambda} \bar{A} - \frac{1}{\lambda} \bar{r}$$

- ▶ λ influences two things:
 - ▶ Slope of AD curve (bigger λ and AD curve is flatter)
 - ▶ Shift of AD curve conditional on IS shock, \bar{A} (bigger λ and AD curve shifts up less; horizontal shift of AD curve unaffected by λ)

λ and the Effects of IS Shocks

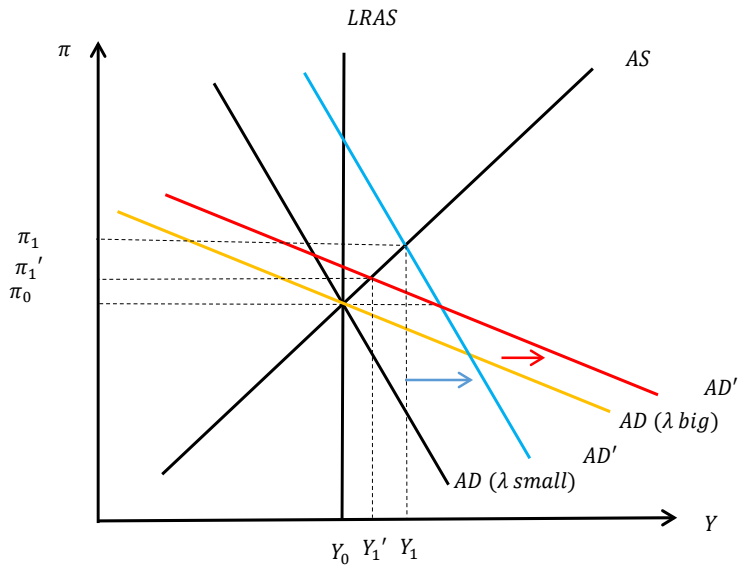

λ and IS Shocks

- ▶ After an increase in \bar{A} , a bigger λ results in:
 1. Smaller increase in π
 2. Smaller increase in Y . Since Y^P doesn't change, this means that the gap, X , goes up by less
- ▶ Bigger λ is a “win-win” from perspective of dual mandate conditional on IS shocks

IS Shock: $\lambda = 1$ vs. $\lambda = 10$

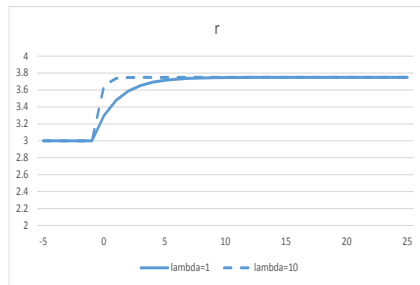
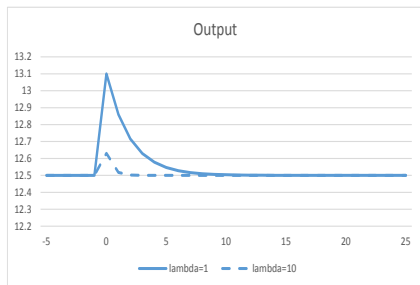
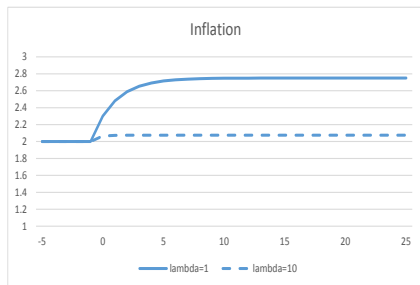

λ and the Effects of Y^P Shocks

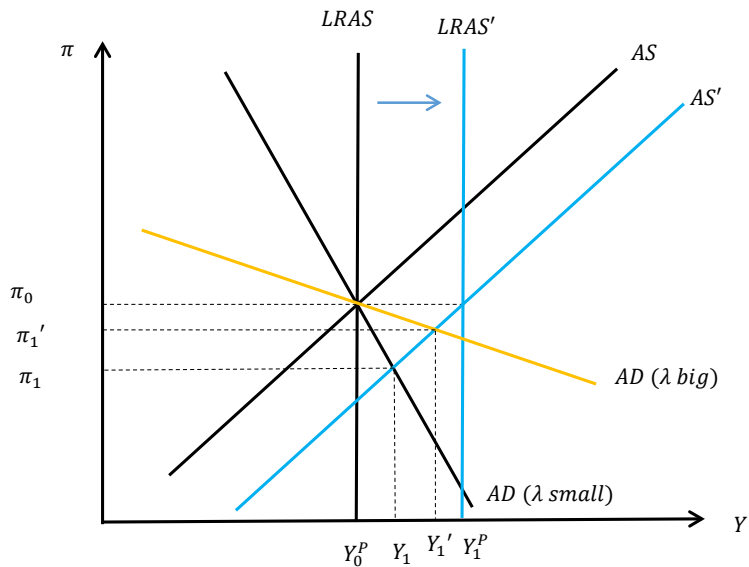

λ and Potential Output Shocks

- ▶ After an increase in Y^P , a bigger λ results in:
 1. Smaller increase in π
 2. Bigger increase in Y . Since Y^P increases, this means that the gap, X , goes down by less the bigger is λ
- ▶ Bigger λ is a “win-win” from perspective of dual mandate conditional on potential output shocks

Y^P Shock: $\lambda = 1$ vs. $\lambda = 10$

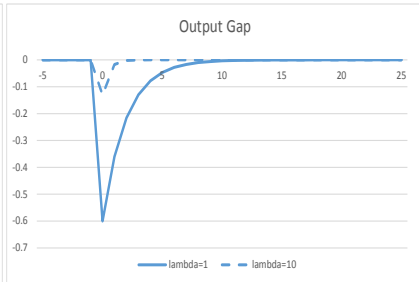
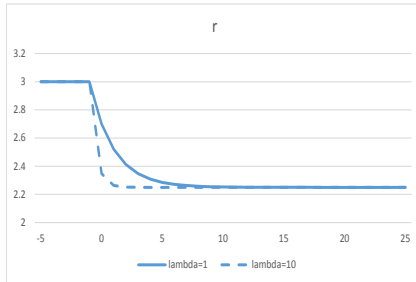
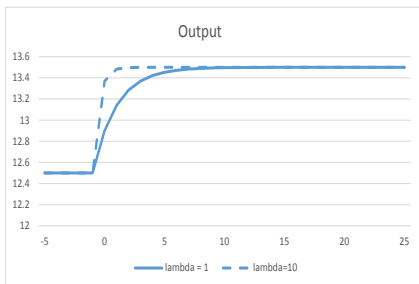
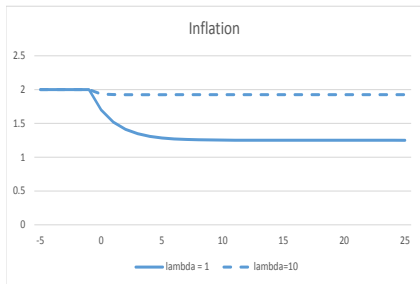

Divine Coincidence

- ▶ Divine Coincidence: there is no tradeoff between objectives of monetary policy
- ▶ Responding strongly to inflation both stabilizes inflation and the output gap
- ▶ So named by **Blanchard and Gali (2007)**
- ▶ Forms the basis of the call for “inflation targeting,” either implicitly or explicitly done by several leading central banks

Average Inflation Targeting

- ▶ In August 2020, in conclusion of its comprehensive **review** of its tools and strategies, the Fed has adopted **average inflation targeting**
- ▶ Basic idea of average inflation targeting: targets average inflation rate of, say, 2 percent, over a several-year window
 - ▶ e.g. if inflation runs at 1 percent one year, the Fed targets 3 percent the next year
- ▶ Basically a way for the Fed to promise **future** monetary stimulus (i.e. future low value of \bar{r})
- ▶ In current AD-AS model, which isn't forward-looking, not obvious why this would matter
- ▶ But in forward-looking model, credible promise of future stimulus could lower long-term rates today, providing stimulus in present and helping to achieve inflation target in present (particularly relevant when ZLB binds)

Breakdown of Divine Coincidence

- ▶ Divine coincidence **does not** hold conditional on inflation shocks (ρ)
 - ▶ Sometimes called “inefficient supply shocks” (do not affect Y^P)
 - ▶ Here, there is a tradeoff between the two aspects of the dual mandate

λ and the Effects of ρ Shocks

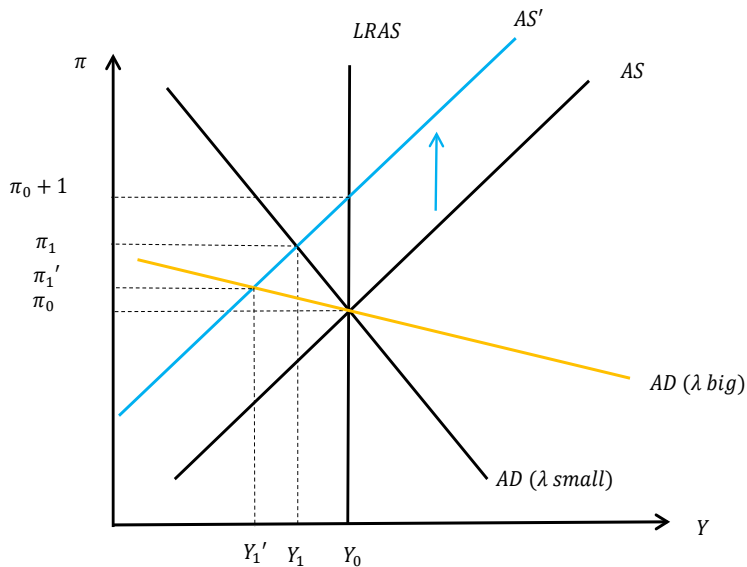

ρ Shock: $\lambda = 1$ vs. $\lambda = 10$

